

Spring Clip

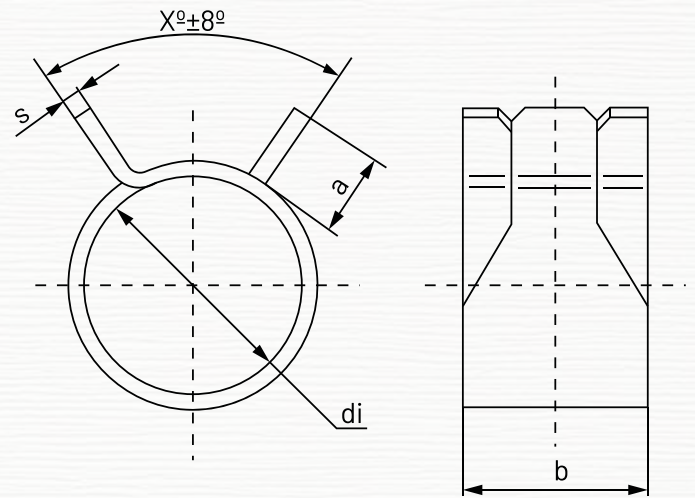



FOR OUTER DIAMETERS (OD)
From **6 mm** up to **20 mm Ø**



Spring clips are designed to distribute pressure uniformly around the application zone, thanks to the material used in their manufacture.

Their use is recommended when the hose is subject to rapid changes in temperature which can cause expansion and contraction of the materials used in the assembly.

These clips are quick and easy to assemble and can even be mounted manually in some cases, without the need for tools.

W1

MATERIAL: C67S W1 Steel
FINISH: Zinc-plated Cr3
CORROSION RESISTANCE: 144 hours Salt Spray
ASTM B-117

Part Number	Ø di ±0.2	b +1 -0.2	a ±0.5	S	Box Quantity	Outer Box Quantity
02014025	5,5	7	3,0	0.5	500	8.000
02014033	6,4	7	3,0	0.5	500	8.000
02014041	7,4	8	3,0	0.6	500	8.000
02014050	8,4	8	3,5	0.6	500	4.000
02014068	9,3	8	3,5	0.7	500	4.000
02014076	10,3	8	5	0.7	500	4.000
02014084	11,1	8	5	0.7	500	4.000
02014092	12,9	8	5	0.8	500	4.000
02014105	13,5	8	5	0.8	500	4.000
02014113	15,3	8	5	0.8	500	4.000
02014121	18,0 ±0.4	8	5	0.8	500	4.000